

---

## TECHNICAL SPECIFICATIONS

---

### B5BX Series

### Air Handler

1.5 - 5.0 Ton Capacity - 60 Cycle

18,000 - 60,000 Btuh (Air Conditioner & Heat Pump)

The B5BX Series of air handlers, when combined with our heat pump or air conditioner, offer a full line of quality, split system heating and cooling equipment.

### FEATURES and BENEFITS

- **Durable, Attractive Cabinet** — Designed using galvanized steel. The door is also galvanized steel, with a polyester urethane finish. The 950 hour salt spray finish resists corrosion 50% better than comparable units. The plastic drain pan is corrosion-resistant.
- **Multi-poised** — Can be used in horizontal, upflow, downflow and vertical applications.
- **Multi-speed** — Gives flexibility of installation.
- **Ease-of-Service** — Plug-in wire connections and built-in filter rack makes the air handler easy to service.
- **Plug-in Heater Kits** — Available in 5kw - 30 kw (Not for use in 115 Volt units)
- **Circuit Board** — Incorporating blower time delay relay, low voltage terminal strip, and heat-strip sequencing.
- **Air Handler Control Board** — Controls time-sequencing of heat stages with field-selectable sequence timing.
- **Breaker Accessibility** — Breaker accessible from front of unit when heater is applied.
- **No Fasteners on Sides or Back** — Smooth surfaces for ease of installation.
- **Cabinet Insulation** — 1" insulation with an R-value of 4.2 contributes to quiet operation and prevents cabinet sweating in difficult applications.

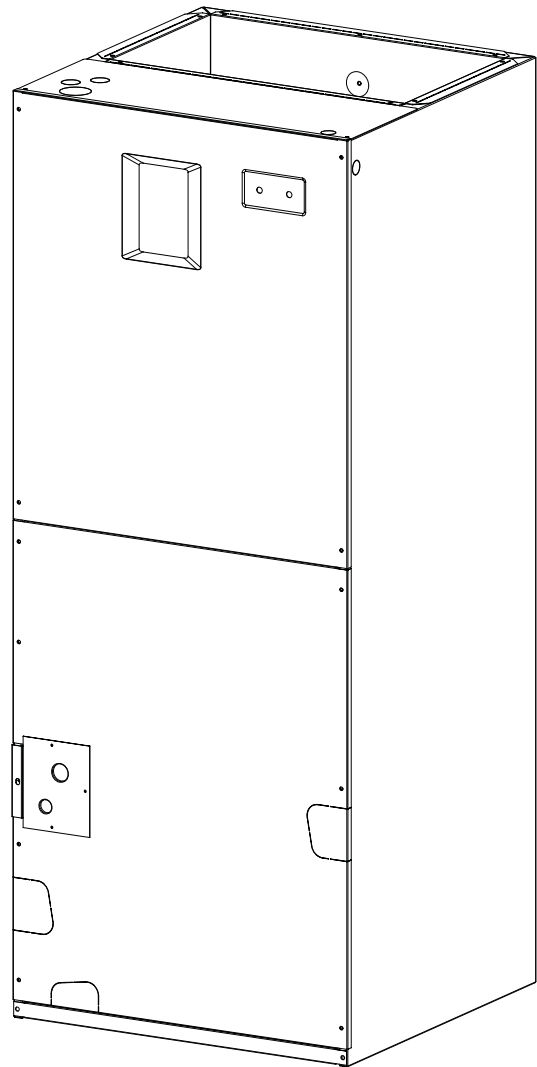

# MODEL IDENTIFICATION CODE - B5BX Air Handler

**EX: B5BX-018/024E**

<b>B</b>	<b>5</b>	<b>B</b>	<b>X</b>	<b>-</b>	<b>018/024</b>	<b>K</b>
Air Handler	Series	Standard Blower Motor	Multipoise Export		Nominal Capacity	Electrical Code Volts-Phase-Cycle 208/230/1/60
					018/024 = 800 CFM    042/048 = 1950 CFM 030/036 = 1200 CFM    060 = 2000 CFM	

## DIMENSIONS

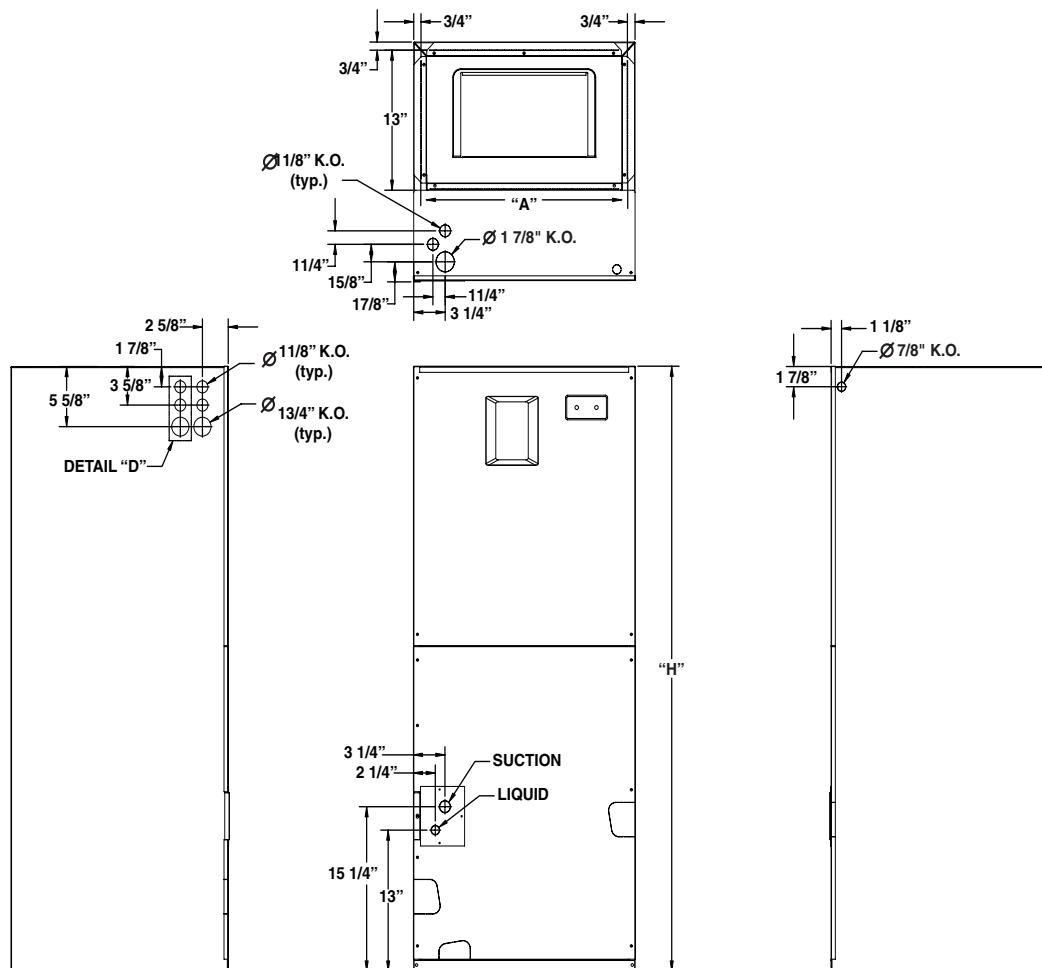

Model	H	W	Refrigerant Connections	
			Suction Dia.	Liquid Dia.
018/024	43 1/2	14 1/4	3/4	3/8
030/036	43 1/2	14 1/4	3/4	3/8
042/048	43 1/2	19 3/4	3/4	3/8
060	49 1/2	19 3/4	7/8	3/8

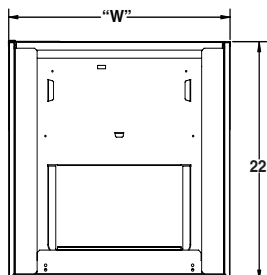

# SPECIFICATIONS - B5BX Air Handler

## 60 Hz

Air Handler B5BX	018/024	030/036	042/048	060
Nominal Cooling Capacity - Btuh (10 SEER H/P)	18,000/ 23,000	28,600/ 34,000	40,000/ 47,000	56,500
Refrigerant Flow Control	Fixed Orifice			
Orifice Size	.051/.060	.063/.067	.075/.080	.093
Maximum Available Auxiliary Heat (kw)	10	10	20	20
Nominal Blower Size (D x W)	10 x 6	10 x 6	10 x 8	10 x 8
(H.P. - Speed - Type)	1/5-3-PSC	1/3-3-PSC	1/3-3-PSC	1/2-3-PSC
Rated External Static Pressure (in. W.C.)	.30	.35	.35	.40
Filter Size (Inches)	12 x 20 x 1	12 x 20 x 1	18 x 20 x 1	18 x 20 x 1
Approximate Shipping Weight (lbs.)	75	85	110	145

## ACCESSORIES - B5BX

Accessory Kit Description	Cabinet Size		Order Number
	A	B	
Downflow Adaptor Kit	X		917342
Single Circuit Adaptor Kit		X	919321
		X	913874

KW	Approved for Cabinet	Order Number	
		with Circuit Breaker(s)	w/o Circuit Breaker(s)
5	A, B	904407	904406
8	A, B	904409	904408
9	A, B	904410*	N/A
10	A, B	904412	904411
15	B	904414	N/A
15	B	904415*	N/A
20	B	904416	N/A

## SYSTEM AIR FLOW DATA - B5BX

Model	HP/wheel	Speed	ESP (" H2O)	CFM Low	CFM Med	CFM High
018/024	1/5 HP 10 X 6	3	0.1	650	780	910
			0.2	610	740	870
			0.3	540	670	800
			0.4	460	600	720
			0.5	370	510	630
030/036	1/3 HP 10 X 6	3	0.1	890	1160	1310
			0.2	880	1150	1300
			0.3	830	1100	1250
			0.4	790	1060	1210
			0.5	740	1030	1180
042/048	1/3 HP 10 x 8	3	0.1	1060	1380	1560
			0.2	1050	1370	1550
			0.3	1000	1310	1480
			0.4	950	1250	1410
			0.5	910	1200	1290
060	1/2 HP 10 X 8	3	0.1	1790	2050	2260
			0.2	1780	2040	2250
			0.3	1720	1980	2200
			0.4	1670	1920	2130
			0.5	1610	1870	2070

\* 3 Phase

### Notes:

- 1) Airflow is shown in cfm, +/- 5%.
- 2) External static pressure is shown in inches w.c.
- 3) All airflows are measured without filter and with dry coil. For filter velocity of 300 ft./min. subtract .08" external static pressure. For wet coil, subtract .1" external static pressure.
- 4) See unit nameplate or installation instructions for maximum recommended external static pressure.

# SYSTEM COOLING & HEATING CAPACITIES

## B5BX Cooling Capacities 60HZ (MBTUH)

Coil Refrigerant Temperature		35 °F			40 °F			45 °F			50 °F			55 °F		
		80/67	76/63	72/59	80/67	76/63	72/59	80/67	76/63	72/59	80/67	76/63	72/59	80/67	76/63	72/59
MODEL	CFM	Evaporator Air- ENTERING DRY BULB/WET BULB TEMPERATURE °F														
1.5/2.0	TC	38.69	33.12	27.59	35.85	26.85	19.96	27.88	23.60	18.06	19.33	18.49	13.13	17.59	11.31	12.54
	SC	23.59	23.01	22.05	20.26	20.78	19.53	19.73	19.37	17.60	15.74	20.19	13.13	16.76	11.31	12.54
2.5/3.0	TC	32.85	28.06	23.35	30.03	23.15	17.54	23.78	19.72	15.68	16.99	15.25	11.21	14.51	9.91	9.84
	SC	19.69	18.99	18.29	16.98	17.02	15.95	15.91	15.71	15.00	12.72	16.03	11.21	14.02	9.91	9.84
3.5/4.0	TC	28.18	24.01	19.96	23.65	18.47	13.88	18.77	15.46	13.20	13.39	11.50	8.52	10.89	7.64	7.11
	SC	16.57	15.77	15.28	13.21	12.86	11.36	11.13	12.78	11.77	8.57	11.55	8.52	11.83	7.64	7.11
5.0	TC	62.44	53.00	43.86	53.86	44.17	34.56	44.41	34.20	25.92	34.13	24.78	20.06	23.58	18.79	14.33
	SC	39.13	37.93	36.08	35.95	34.33	31.52	32.63	30.02	25.83	28.88	24.62	20.06	23.36	18.79	14.33
1950	TC	61.00	51.77	42.78	52.60	43.09	33.72	43.31	33.56	25.27	32.90	24.16	19.54	23.00	18.30	13.96
	SC	38.19	36.96	35.07	35.00	33.36	30.67	31.70	29.19	25.17	27.70	23.98	19.54	22.75	18.30	13.96
1810	TC	57.65	48.90	40.37	49.58	40.66	31.82	40.73	31.38	23.74	30.95	22.70	18.31	21.60	17.14	13.10
	SC	35.90	34.64	32.78	32.83	31.18	28.68	29.51	27.24	23.62	25.82	22.49	18.31	21.30	17.14	13.10
1660	TC	84.24	72.18	60.47	73.73	61.33	48.83	61.75	48.97	37.30	48.75	35.84	29.13	34.33	27.52	21.27
	SC	52.91	51.63	50.01	49.10	47.67	44.49	45.39	42.84	37.12	40.91	35.44	29.13	33.82	27.52	21.27
2000	TC	77.92	66.74	55.84	68.16	56.62	45.06	57.01	45.02	34.36	44.82	33.02	26.79	31.62	25.30	19.56
	SC	48.69	47.59	45.95	45.20	43.77	40.87	41.69	39.14	34.18	37.36	32.60	26.79	31.10	25.30	19.56
1910	TC	75.44	64.60	53.96	65.95	54.70	43.52	55.07	43.30	33.12	43.10	31.82	25.77	30.46	24.32	18.81
	SC	46.86	45.89	44.15	43.52	42.04	39.26	40.04	37.37	32.92	35.63	31.37	25.77	29.92	24.32	18.81
1750	TC	84.62	72.12	59.89	70.73	58.59	48.98	60.87	48.23	35.98	47.44	34.77	34.77	33.97	28.88	21.13
	SC	52.29	50.99	48.05	48.91	48.33	45.61	45.68	42.55	38.36	41.55	35.23	30.77	33.36	28.88	21.13
1750	TC	82.20	70.12	58.23	68.94	57.07	47.53	59.06	46.63	34.93	46.14	33.75	33.33	32.91	27.85	20.44
	SC	50.60	49.40	46.63	47.43	46.84	44.03	44.25	40.91	37.06	40.10	34.11	29.69	32.28	27.85	20.44
1750	TC	77.82	66.39	55.08	65.54	54.15	44.84	55.84	43.80	32.98	43.44	31.85	30.77	30.97	25.99	19.18
	SC	47.59	46.56	43.87	44.60	43.84	41.13	41.44	38.00	34.72	37.16	32.05	27.71	30.33	25.99	19.18



286C-0807 (Replaces 286C-1006)

Before purchasing this appliance, read important energy cost and efficiency information available from your retailer. Specifications and illustrations subject to change without notice and without incurring obligations.

Printed in U.S.A. (08/07)